

Identsystem CIS3/CIS3A

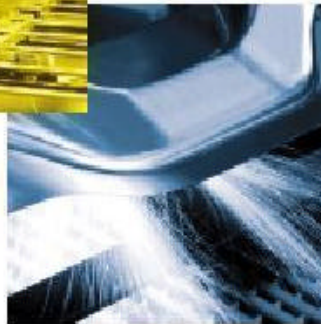

More than safety.

EUCHNER GmbH + Co.
P.O. Box 10 01 52
D- 70745 LeinfeldenEchterdingen
Germany

Phone +49/711/75 97-0
Fax +49/711/75 33 16
www.euchner.de
info@euchner.de



EUCHNER

EUCHNER – Your Partner for Industrial Electrical Equipment and Electronics

Since its foundation in 1940, EUCHNER has been designing and developing switchgear for controlling diverse motion sequences in the field of machine construction and terotechnology. An innovative development in 1952 was the world's first multiple position switch.

The EUCHNER product range includes everything from electromechanical and electronic equipment through to systems and services.

Reliability, precision and quality are tested continually and maintained at a high level by computer-controlled development, test and inspection systems for hardware and software.

EUCHNER products are sold by competent partners all over the world. Close and optimum contact with our customers is ensured by a large network of sales agencies, EUCHNER sales offices and our in-house product specialists.

We therefore can solve specific problems on-site at any time. An overview of our Technical Sales Offices is given on the last page.



Leinfelden/Stuttgart

Administration/Sales/Development/Production



Bad Überkingen

Production of electromechanical precision switches

Quality made by EUCHNER



Reg.-No. 4438-01

EUCHNER

EUCHNER GmbH + Co.

Industrial Electrics and Electronics

Kohlhammerstraße 16
D-70771 Leinfelden-Echterdingen

Telephone: 07 11 / 75 97-0
Telefax: 07 11 / 75 33 16

www.euchner.de
info@euchner.de

Table of Content

| | Page |
|--|-----------|
| System Overview | 4 |
| General terms concerning the Identsystems CIS3 / CIS3A | 4 |
| The difference between CIS3 and CIS3A | 4 |
| Block diagram CIS3 | 5 |
| Block diagram CIS3A | 5 |
| | |
| Identsystem CIS3 | 6 |
| CIS3 Data Carrier (rectangular design, screw fixing) | 6 |
| CIS3 Data Carrier (round design, bonding fixing) | 7 |
| CIT3PL... Read-Only Head (cable version) | 8 |
| CIT3PL... Read-Only Head (plug and socket version) | 9 |
| CIT3SX... Read/Write Head | 10 |
| | |
| Identsystem CIS3A | 11 |
| CIS3A Data Carrier (rectangular design, screw fixing) | 12 |
| CIT3APL... Read-Only Head (cable version) | 13 |
| CIT3A Read-Only Head highly dynamic (plug and socket version) | 14 |
| CITA3SX... Read/Write Head | 15 |
| | |
| Appendix A: Pulse Timing Diagram of CIT3... read-only heads | 16 |
| | |
| Mobile Hand-Held Terminal CIP3-H2 / CIP3A-H2 | 17 |

System Overview

General terms concerning the Identsystems CIS3 / CIS3A

The inductive identsystems CIS3 / CIS3A permit contactless identification of pallets, workpieces, production transport systems and any parts which flow in a dynamic manufacturing environment.

The data carriers which need no battery are written (programmed) and read via an inductive coupling **without physical contact** and therefore **absolutely wear free**.

Read-only heads with parallel interface and **read/write heads with serial (RS232) interface** are also available.

The information can be **stored** on the **data carrier** on an E²PROM memory chip **for over 20 years without the need for batteries**. The storage capacity is **16 bytes**, corresponding to **32 decimal digits**.

The **read-only head** interface is **24 V parallel**, is low cost, easily handled and can be interrogated by **any PLC using standard I/O**.

No further adapter modules are needed.

A PLC module with **serial interface is not required**.

The **read/write head** features a serial RS232 interface. Data transfer is handled on the basis of the 3964R protocol, thus allowing easy integration into the most popular PLC control types. The read/write heads also requires **no external adapter modules**.

A **convenient WINDOWS[®]-compatible PC software package** is available for data carrier programming outside of the system.

The difference between CIS3 and CIS3A

The only difference between the versions CIS3 and CIS3A is, that with the Identsystem CIS3A you can realize double writing and reading distance as with the Identsystem CIS3. The case forms of the read-only and the read/write heads are absolutely identical for the Identsystems CIS3 and CIS3A. Attention must be paid to the fact that the devices should be not exchanged among each other, i.e. a data carrier of the CIS3A family cannot be read with a read-only head of the CIS3 family!

The reason for this is the difference in the forms of the antennas. I.e. the antenna form of the Identsystem CIS3 is rod shaped and the antenna form of the Identsystem CIS3A is round. Therefore both systems are not compatible with each other. The rod shaped antenna form of the Identsystem CIS3 is especially made for dynamical reading.

The identsystems CIS3 / CIS3A afford the following advantages

- Low-cost read/write system with separate read-only head
- Read/write head with serial RS232 interface and 3964R protocol
- Easy connection of the read-only head to the higher-level control by 24 V parallel interface
- This also allows easy integration in any field bus system
- Compact head design
- No external adapter module required
- Storage capacity 16 bytes
- Read distance 0 ... 40 mm
- Capable of dynamic reading at a speed of up to 90 m/min
- Long time proven techniques of the automotive industry (immobilizer)

Block diagram Identsystem CIS3

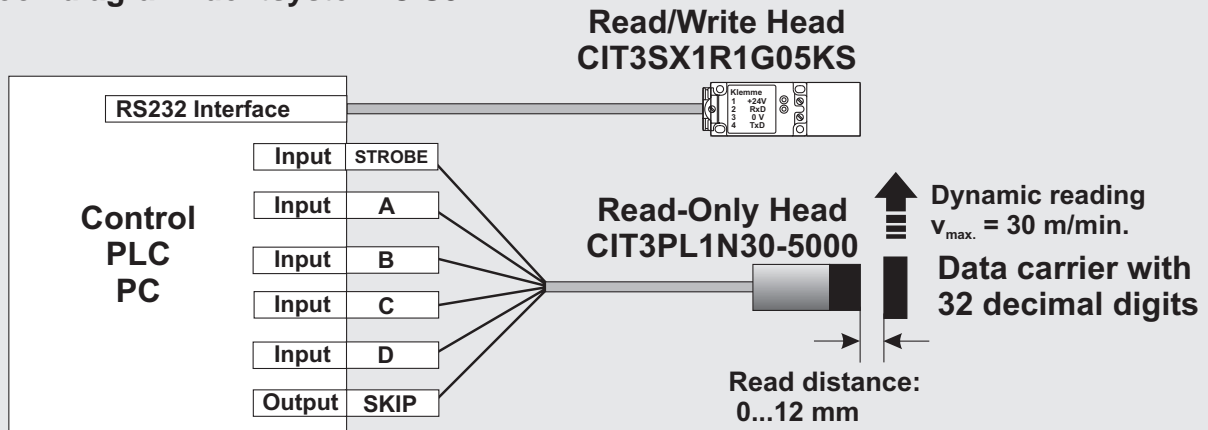

Block diagram Identsystem CIS3A

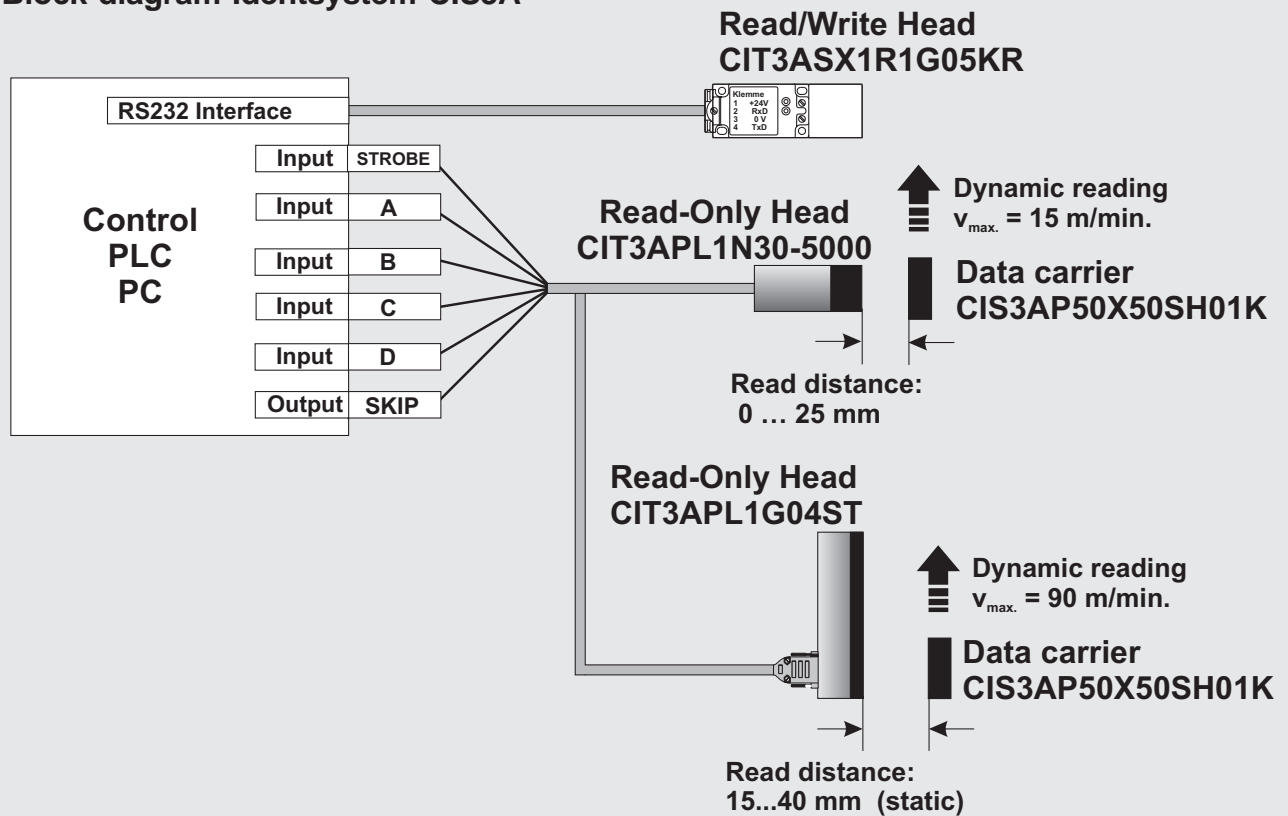

CIS3 Demo Kit

For testing purpose we are offering our Identsystems CIS3 and CIS3A as a demo kit. These demo kits contains everything what you need for testing of the Identsystems CIS3 and CIS3A **quickly, at full functionality and without time intensive programming and installation works.**

You can order this demo kit under the Cat. No. 077 755.

CIS3 System Manual

Please order detailed documentation on the EUCHNER Identsystems CIS3 / CIS3A under the Cat. No. 071 652.

CIS3 Data Carrier (other versions currently in preparation or available on request)

Horizontal data carrier

Type designation: CIS3P35X16SH01KH

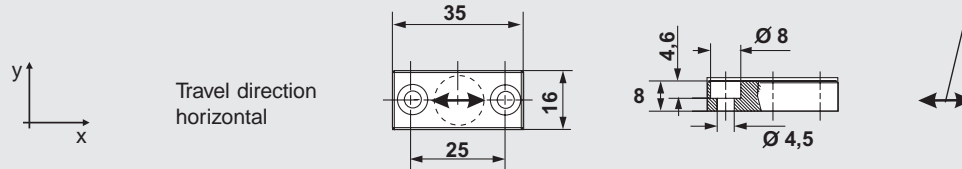

Note on installation:

When mounting the reading head / data carrier make sure that the travel direction is in accordance with the arrow direction on the active area of the reading head.

Unprogrammed:

| |
|----------|
| Cat. No. |
| 040 045 |

Programmed *:

| |
|----------|
| Cat. No. |
| 071 745 |

All dimensions in mm

Vertical data carrier

Type designation: CIS3P35X16SH01KV

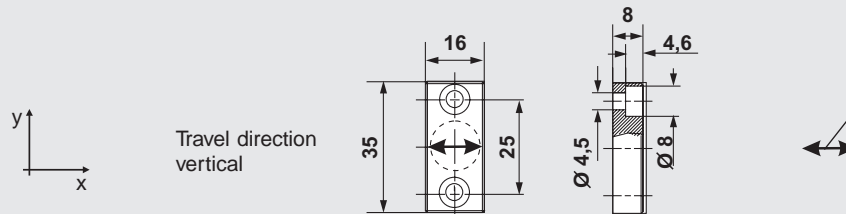

Note on installation:

When mounting the reading head / data carrier make sure that the travel direction is in accordance with the arrow direction on the active area of the reading head.

Unprogrammed:

| |
|----------|
| Cat. No. |
| 040 046 |

Programmed *:

| |
|----------|
| Cat. No. |
| 071 746 |

All dimensions in mm

* The data carrier can be programmed with a maximum 32-digit customized decimal number at special request. In addition, the programmed code is laser-inscribed indelibly and in plain text on the side of the carrier. If less than 32 decimal digits are programmed, the remaining positions are programmed with E_{hex} (filler bits). Any other filler bit may also be programmed on request.

Technical Data

| General parameter | Value | | | Unit |
|---|------------------------------------|------|------|--------|
| | min. | nom. | max. | |
| Storage capacity: (32 decimal digits) | | 128 | | bit |
| Power supply | inductive via read head | | | |
| Housing | Plastic - PPS | | | |
| Environmental protection | IP 67 | | | |
| Installation method | Screw fixing, flush on or in metal | | | |
| Operating temperature | -40 | | +85 | °C |
| Storage temperature | -40 | | +125 | °C |
| Data retention time (T = +22 °C) | 20 | | | years |
| Operating parameter for reading with | | | | |
| - Read-only head CIT3PL1N30-xxxx | | | | |
| - Read/write head CIT3SX... | | | | |
| Read distance sL | 0 | | 12 | mm |
| Center offset in x direction (s = 9 mm and T = +25°C) | ±10 | ±15 | | mm |
| Center offset in y direction (s = 9 mm and T = +25°C) | | ±3 | | mm |
| Number of read cycles | unlimited | | | |
| Operating parameter for writing with | | | | |
| - Read/write head CIT3SX... | | | | |
| Write distance sS | 0 | 4 | 5 | mm |
| Number of write cycles (T = -40°C ... +22°C) | 5 x 10 ⁴ | | | cycles |

CIS3 Data Carrier (other versions currently in preparation or available on request)

Data carrier round

Type designation: CIS3P16D08KH01K

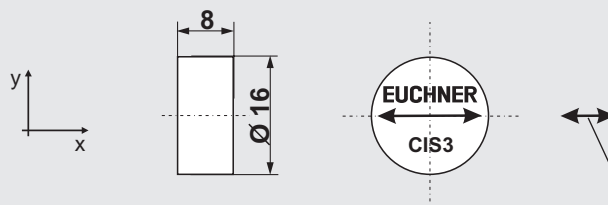

Mounting adhesives:

1. 2-component epoxy adhesive
 - 1.1 UHU-Plus
 - 1.2 Scotch-Weld 1614BA/3520BA/3533BA or comparable
2. Aneorobe adhesive
 - 2.1 Loctite 648 or comparable

Note on installation:

When mounting the reading head / data carrier make sure that the travel direction is in accordance with the arrow direction on the active area of the reading head.

Unprogrammed:

| |
|-----------------|
| Cat. No. |
| 071 865 |

Programmed *:

| |
|-----------------|
| Cat. No. |
| 071 867 |

All dimensions in mm

- * The data carrier can be programmed with a maximum 32-digit customized decimal number at special request. In addition, the programmed code is laser-inscribed indelibly and in plain text on the side of the carrier.
 If less than 32 decimal digits are programmed, the remaining positions are programmed with E_{hex} (filler bits). Any other filler bit may also be programmed on request.

Technical Data

| General parameter | Value | | | Unit |
|--|--------------------------------------|------|------|--------|
| | min. | nom. | max. | |
| Storage capacity: (32 decimal digits) | | 128 | | bit |
| Power supply | inductive via read head | | | |
| Housing | Plastic - PPS | | | |
| Environmental protection | IP 67 | | | |
| Installation method | Bonding fixing, flush on or in metal | | | |
| Operating temperature | -40 | | +85 | °C |
| Storage temperature | -40 | | +125 | °C |
| Data retention time (T = +22 °C) | 20 | | | years |
| Operating parameter for reading with - Read-only head CIT3PL1N30-xxxx - Read/write head CIT3SX... | | | | |
| Read distance sL | 0 | | 10 | mm |
| Center offset in x direction (s = 9 mm and T = +25°C) | ±8 | ±13 | | mm |
| Center offset in y direction (s = 9 mm and T = +25°C) | | ±3 | | mm |
| Number of read cycles | unlimited | | | |
| Operating parameter for writing with - Read/write head CIT3SX... | | | | |
| Write distance sS | 0 | 4 | 5 | mm |
| Number of write cycles (T = -40°C ... +22°C) | 5 x 10 ⁴ | | | cycles |

CIT3 Read-Only Head

Cat. No.

040 085

CIT3PL1N30-5000 read-only head

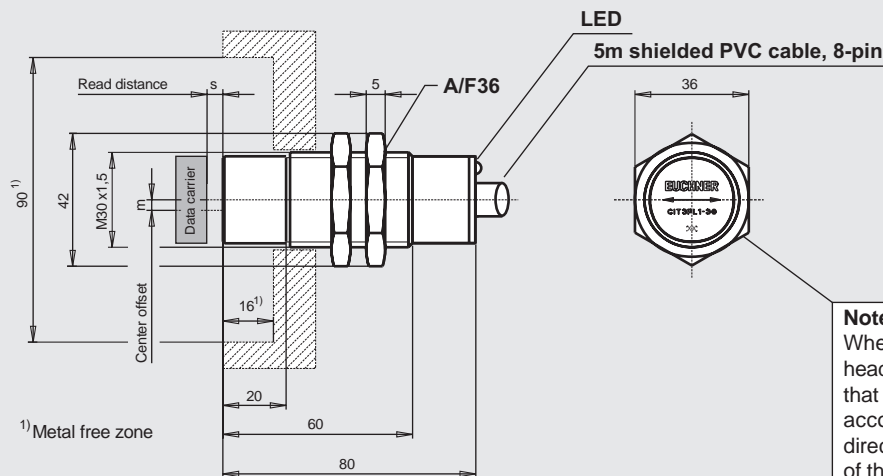

Note on installation:
When mounting the reading head / data carrier make sure that the travel direction is in accordance with the arrow direction on the active area of the reading head.

| | | | | | | | | | |
|---------------------|--------|---------|-------|--------|------|------|------|--------|---------|
| Cable colour | white | brown | green | yellow | grey | pink | blue | red | transp. |
| Connection / signal | 0V/GND | 24 V/UB | A | B | C | D | SKIP | STROBE | shield |

All dimensions in mm

Note:

The connecting cable can be extended with a shielded cable up to a length of max. 50m.

Technical Data

| General parameter | Value | | | Unit |
|---|----------------------|-------|-------|----------|
| | min. | nom. | max. | |
| Read-only head CIT3PL1N30-5000 | | | | |
| Housing | Brass, nickel plated | | | |
| Environmental protection | IP 67 | | | |
| Temperature range | 0 | | +50 | °C |
| Installation method | non-flush | | | |
| Operating voltage U_B (regulated, residual ripple < 5 %) | 20 | 24 | 28 | V= |
| Permanent current consumption (not including load current) | | 80 | 100 | mA |
| Load current per output | | | 30 | mA |
| Output voltage | | | | |
| A, B, C, D, STROBE = 1 (HIGH level) | $U_B - 2 V$ | | | V= |
| A, B, C, D, STROBE = 0 (LOW level) | | | 2 | V= |
| Input voltage: SKIP = 1 (HIGH level) | 15 | | U_B | V= |
| Input voltage: SKIP = 0 (LOW level) | 0 | | 2 | V= |
| Input resistance R_i (SKIP input) | | 4500 | | Ω |
| Operating parameter for reading | | | | |
| Max. read distance s_L (for more information please see page 6 and 7) | | | 12 | mm |
| Response time for reading 4 decimal digits | | | 112 | ms |
| Read time for each further decimal digit (digits 5 to 32) | | | 2 | ms |
| Relative speed for reading 4 decimal digits (at $s = 10$ mm and y offset = 0 mm) | 0 | | 30 | m/min |
| Speed reduction for each further decimal digit (at $s = 10$ mm) | 0.25 | 0.625 | 1.5 | m/min |

CIT3 Read-Only Head (plug and socket version)

| Cable length | Cat. No. |
|--------------|----------|
| 5 m | 071 781 |
| 10 m | 077 727 |
| 15 m | 077 729 |

CIT3PL1N30-STxx read-only head (xx = cable length in m, 5m/10m/15m available)

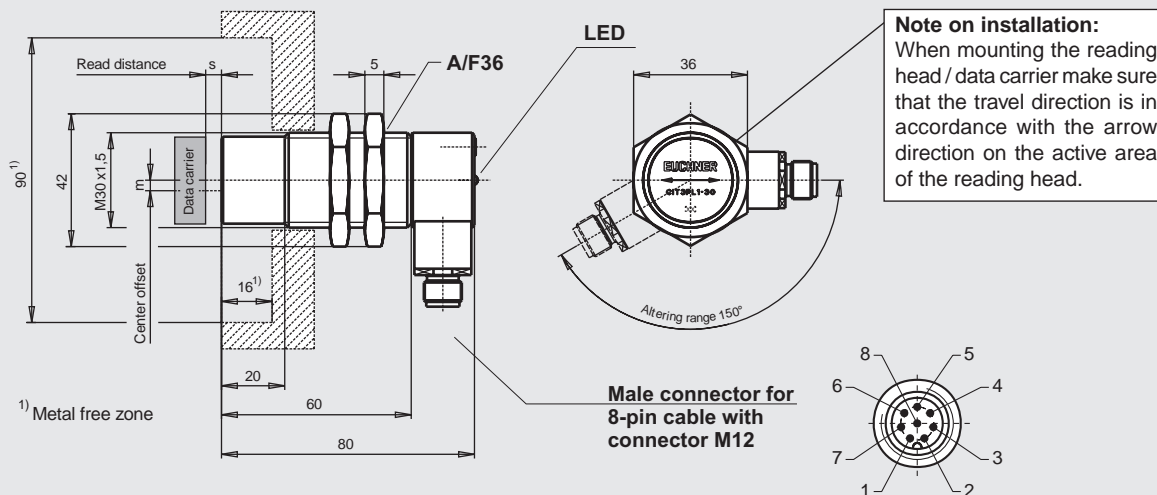

| | | | | | | | | | |
|---------------------|--------|---------|-------|--------|------|------|------|--------|---------|
| Cable colour | white | brown | green | yellow | grey | pink | blue | red | transp. |
| Pin | 1 | 2 | 3 | 4 | 5 | 6 | 7 | 8 | shield |
| Connection / signal | 0V/GND | 24 V/UB | A | B | C | D | SKIP | STROBE | shield |

All dimensions in mm

Note:

The dispatch of these read-only heads is executed completely with corresponding assembled 8-pole shielded connecting cable in the lengths of 5m, 10m or 15m. The connecting cable can be extended with a shielded cable up to a length of max. 50m.

Technical Data

| General parameter | Value | | | Unit |
|---|----------------------|-------|-------|----------|
| | min. | nom. | max. | |
| Read-only head CIT3PL1N30-STxx | | | | |
| Housing | Brass, nickel plated | | | |
| Environmental protection | IP 67 | | | |
| Temperature range | 0 | | +50 | °C |
| Installation method | non-flush | | | |
| Operating voltage U_B (regulated, residual ripple < 5 %) | 20 | 24 | 28 | V= |
| Permanent current consumption (not including load current) | | 80 | 100 | mA |
| Load current per output | | | 30 | mA |
| Output voltage | | | | |
| A, B, C, D, STROBE = 1 (HIGH level) | $U_B - 2 V$ | | | V= |
| A, B, C, D, STROBE = 0 (LOW level) | | | 2 | V= |
| Input voltage: SKIP = 1 (HIGH level) | 15 | | U_B | V= |
| Input voltage: SKIP = 0 (LOW level) | 0 | | 2 | V= |
| Input resistance R_i (SKIP input) | | 4500 | | Ω |
| Operating parameter for reading | | | | |
| Max. read distance s_L (for more information please see page 6 and 7) | | | 12 | mm |
| Response time for reading 4 decimal digits | | | 112 | ms |
| Read time for each further decimal digit (digits 5 to 32) | | | 2 | ms |
| Relative speed for reading 4 decimal digits (at $s = 10$ mm and y offset = 0 mm) | 0 | | 30 | m/min |
| Speed reduction for each further decimal digit (at $s = 10$ mm) | 0.25 | 0.625 | 1.5 | m/min |

CIT3 Read/Write Head

| |
|----------|
| Cat. No. |
| 040 091 |

CIT3SX1R1G05KS read/write head with serial interface V.24 / RS232

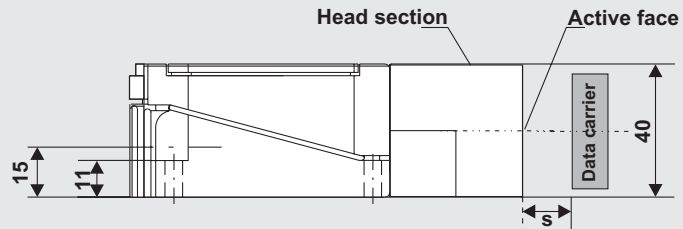
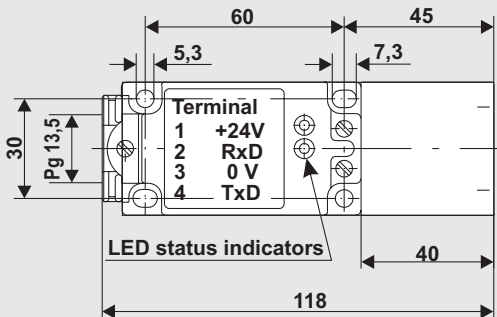

Type G05, adjustable head with 5 active face locations

Note on installation:
When mounting the read/write head / data carrier make sure that the travel direction is in accordance with the arrow direction on the active area of the read/write head.

All dimensions in mm

The robust housing with the environmental protection IP65 agrees of the standard EN 50 041 with regard to its size. The head consists of 3 units which permits problem-free and simple assembly.

The individual commands for reading and writing the data carriers follow the conventional 3964R protocol and are described in the EUCHNER CIS3 system manual (Cat. No. 071 652).

A convenient WINDOWS®-compatible PC software is available for data carrier programming.*

Technical Data

| General parameter | Value | | | Unit |
|--|--|------|------|-------|
| | min. | nom. | max. | |
| Read/write head CIT3SX1R1G05KS | | | | |
| Housing | plastic | | | |
| Environmental protection | IP 65 | | | |
| Storage temperature | -25 | +70 | +80 | °C |
| Operating temperature | 0 | +22 | +50 | °C |
| Operating voltage U_B (regulated, residual ripple < 2 %) | 20 | 24 | 25 | V= |
| Current consumption | | 120 | 140 | mA |
| Connection type | screw terminal | | | |
| Operating parameter when writing and reading | | | | |
| Max. read distance s_L (for more information please see page 6 and 7) | | | 12 | mm |
| Max. write distance s_S (for more information please see page 6 and 7) | | | 6 | mm |
| Write time for 4 decimal digits (= 2 byte) | | 160 | 230 | ms |
| Write time for 32 decimal digits (= 16 byte) | | 350 | 420 | ms |
| Interface, data transfer, documentation | | | | |
| Interface | RS232 / V.24 | | | |
| Protocol | 3964R | | | |
| Data rate | | 9.6 | | kBaud |
| Parity | even | | | |
| Cable length (RS232 interface) | | | 5 | m |
| Manual for protocol 3964R | Cat. No. 071 652 | | | |
| * PC software for programming data carriers | on request or can be downloaded from the Internet http://www.euchner.de File: cip3_p_e.exe | | | |

Identsystem CIS3A

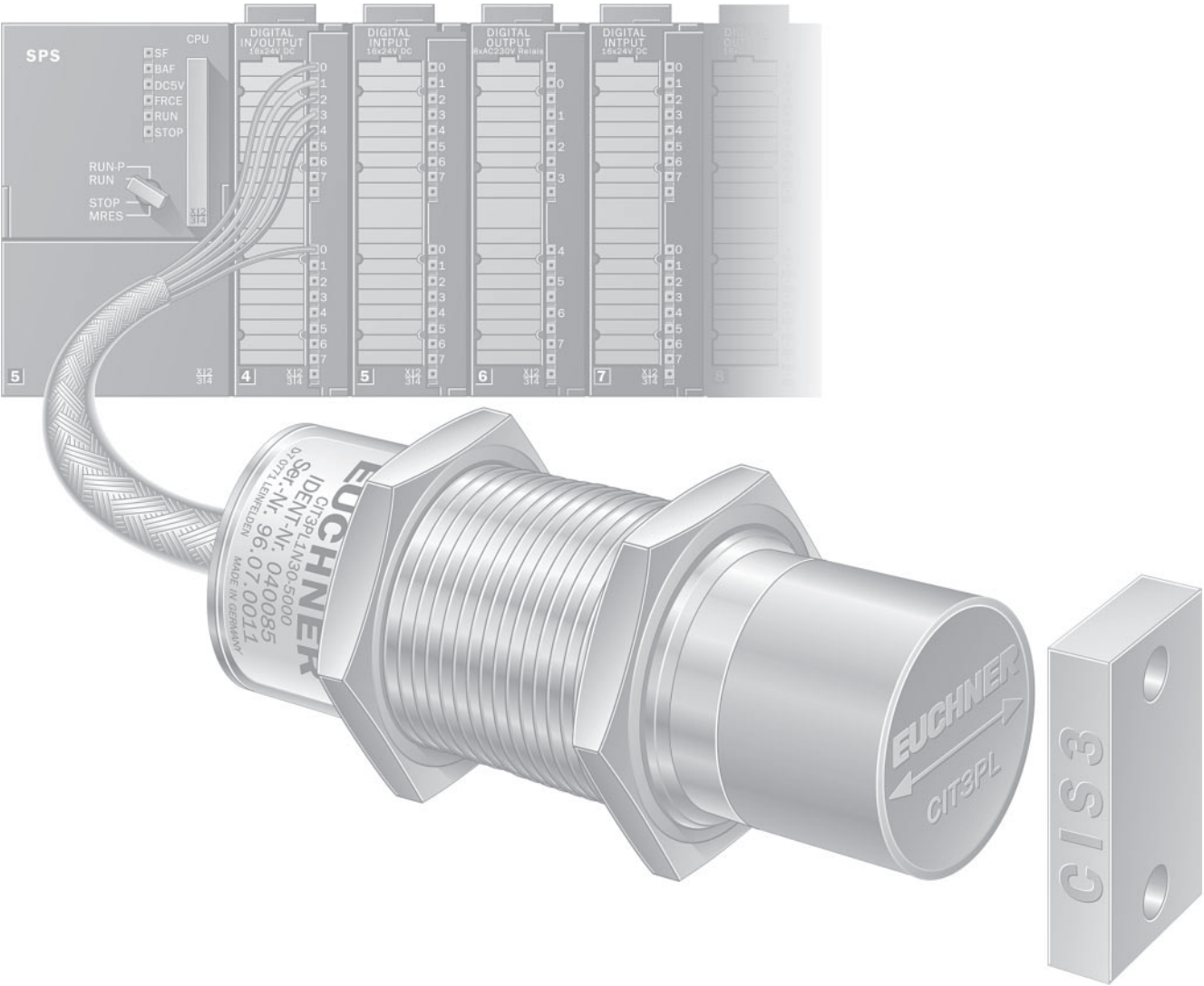

CIS3A Data Carrier (other versions currently in preparation or available on request)

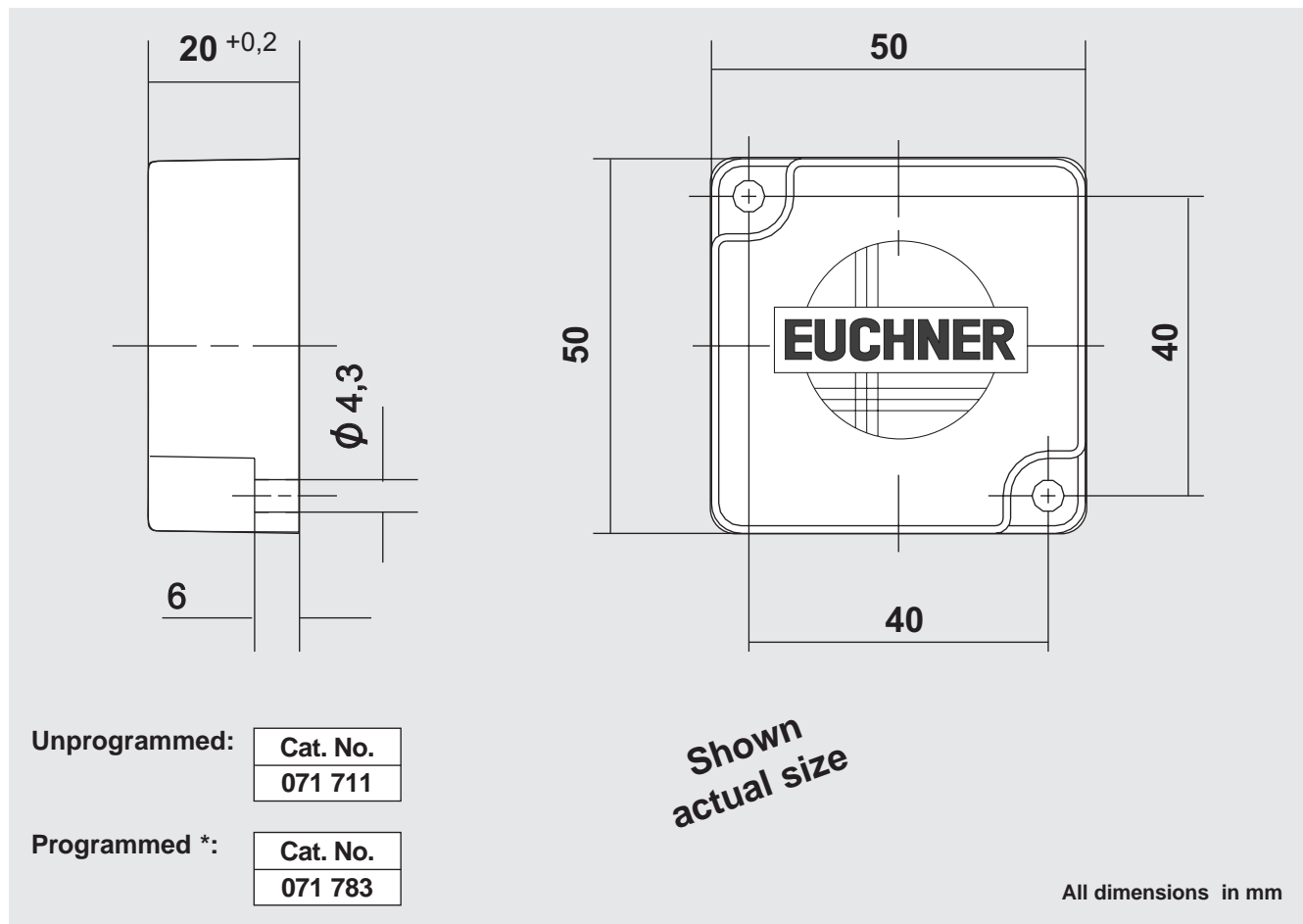

* The data carrier can be programmed with a maximum 32-digit customized decimal number at special request. In addition, the programmed code is laser-inscribed indelibly and in plain text on the side of the carrier. If less than 32 decimal digits are programmed, the remaining positions are programmed with E_{hex} (filler bits). Any other filler bit may also be programmed on request.

Technical Data

| General parameter | Value | | | Unit |
|--|------------------------------------|------|------|--------|
| | min. | nom. | max. | |
| Storage capacity: (32 decimal digits) | | 128 | | bit |
| Power supply | inductive via read head | | | |
| Housing | Plastic - PPS | | | |
| Environmental protection | IP 67 | | | |
| Installation method | Screw fixing, flush in or on metal | | | |
| Operating temperature | -40 | | +85 | °C |
| Storage temperature | -40 | | +125 | °C |
| Data retention time (T = +22 °C) | 20 | | | years |
| Operating parameter for reading with | | | | |
| - Read-only head CIT3APL1N30-xxxx | | | | |
| - Read/write head CIT3ASX... | | | | |
| Read distance sL | 0 | 22 | 25 | mm |
| Center offset m (at reading distance s = 9 mm and T = +25°C) | | ±10 | | mm |
| Number of read cycles | unlimited | | | |
| Operating parameter for reading with | | | | |
| - Read-only head CIT3APL1G04-ST | | | | |
| Read distance sL | 15 | | 40 | mm |
| Operating parameter for writing with | | | | |
| - Read/write head CIT3ASX... | | | | |
| Write distance sS | 0 | 11 | 13 | mm |
| Number of write cycles (T = -40°C ... +22°C) | 5 x 10 ⁴ | | | cycles |

CIT3A Read-Only Head

| |
|----------|
| Cat. No. |
| 071 700 |

Read-only head CIT3APL1N30-5000

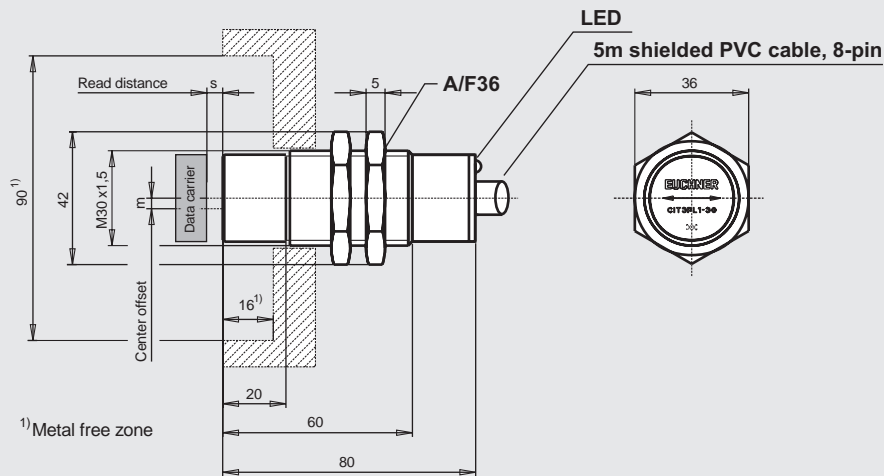

| | | | | | | | | | |
|---------------------|--------|---------|-------|--------|------|------|------|--------|---------|
| Cable colour | white | brown | green | yellow | grey | pink | blue | red | transp. |
| Connection / signal | 0V/GND | 24 V/UB | A | B | C | D | SKIP | STROBE | shield |

All dimensions in mm

Note:

The connecting cable can be extended with a shielded cable up to a length of max. 50m.

Technical Data

| General parameter | Value | | | Unit |
|--|----------------------|-------|-------|----------|
| | min. | nom. | max. | |
| Read-only CIT3APL1N30-5000 | | | | |
| Housing | Brass, nickel plated | | | |
| Environmental protection | IP 67 | | | |
| Temperature range | 0 | | +50 | °C |
| Installation method | non-flush | | | |
| Operating voltage U_B (regulated, residual ripple < 5 %) | 20 | 24 | 28 | V= |
| Permanent current consumption (not including load current) | | 80 | 100 | mA |
| Load current per output | | | 30 | mA |
| Output voltage | | | | |
| A, B, C, D, STROBE = 1 (HIGH level) | $U_B - 2 V$ | | | V= |
| A, B, C, D, STROBE = 0 (LOW level) | | | 2 | V= |
| Input voltage: SKIP = 1 (HIGH level) | 15 | | U_B | V= |
| Input voltage: SKIP = 0 (LOW level) | 0 | | 2 | V= |
| Input resistant R_i (SKIP input) | | 4500 | | Ω |
| Operating parameter for reading | | | | |
| Max. read distance s_L (for more information please see page 12) | | | 25 | mm |
| Response time for reading 4 decimal digits | | | 112 | ms |
| Read time for each further decimal digit (digits 5 to 32) | | | 2 | ms |
| Relative speed for reading 4 decimal digits (at $s = 10$ mm and $m = 0$ mm) | 0 | | 15 | m/min |
| Speed reduction for each further decimal digit (at $s = 10$ mm) | 0.25 | 0.625 | 1.5 | m/min |

CIT3A Read-Only Head

(exceptionally dynamic - up to 90 m/min reading speed)

Cat. No.

071 880

Read-only head CIT3APL1G04-ST

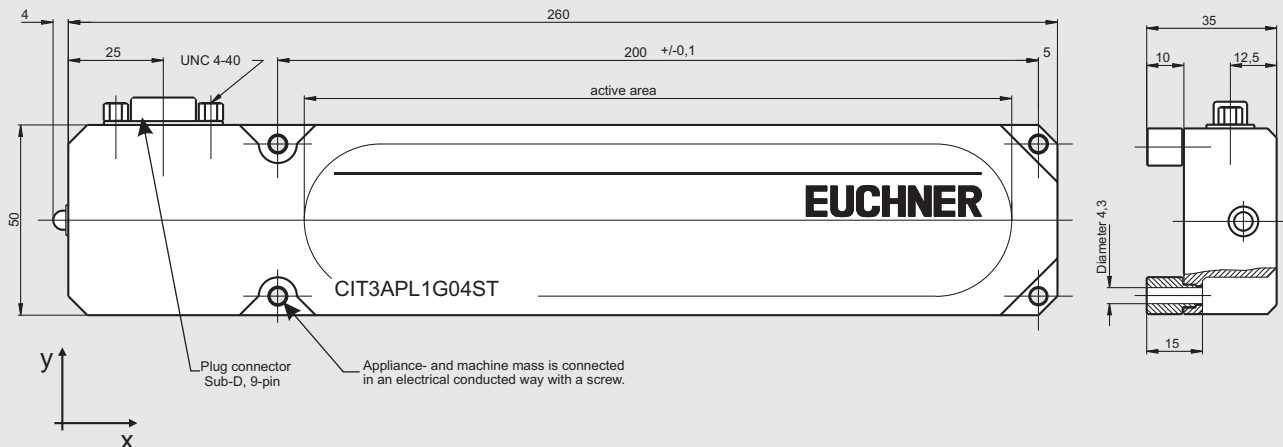

All dimensions in mm

Note:

The connecting cable can be extended with a shielded cable up to a length of max. 50m.

Technical Data

| General parameter | Value | | | Unit |
|--|--------------------|----------|-------|----------|
| | min. | nom. | max. | |
| Read-only head CIT3APL1G04ST | | | | |
| Housing | Plastic - PVC | | | |
| Environmental protection (with special plug connector) | IP 67 | | | |
| Temperature range | -5 | | +50 | °C |
| Installation method | non-flush on metal | | | |
| Operating voltage U_B (regulated, residual ripple < 5 %) | 20 | 24 | 28 | V= |
| Permanent current consumption (not including load current) | | 80 | 100 | mA |
| Load current per output | | | 30 | mA |
| Output voltage | | | | |
| A, B, C, D, STROBE = 1 (HIGH level) | $U_B - 2 V$ | | | V= |
| A, B, C, D, STROBE = 0 (LOW level) | | | 2 | V= |
| Input voltage: SKIP = 1 (HIGH level) | 15 | | U_B | V= |
| Input voltage: SKIP = 0 (LOW level) | 0 | | 2 | V= |
| Input resistant R_i (SKIP input) | | 4500 | | Ω |
| Operating parameter for reading | | | | |
| Max. read distance s_L (for more information please see page 12) | 15 | | 40 | mm |
| Center offset in y direction (at $s = 15\text{mm}$ and $T = +25^\circ\text{C}$) | | ± 12 | | mm |
| Response time for reading 4 decimal digits | | | 112 | ms |
| Read time for each further digit (digits 5 to 32) | | | 2 | ms |
| Relative speed (in x direction) for reading of 4 decimal digits (at $s = 15\text{ mm}$ and $m = 0\text{ mm}$) | 0 | | 90 | m/min |
| Speed reduction for each further decimal digit (at $s = 15\text{ mm}$) | 0.6 | | 1.8 | m/min |

CIT3A Read/Write Head

| |
|----------|
| Cat. No. |
| 040 090 |

Read/write head CIT3ASX1R1G05KR with serial interface V.24 / RS232

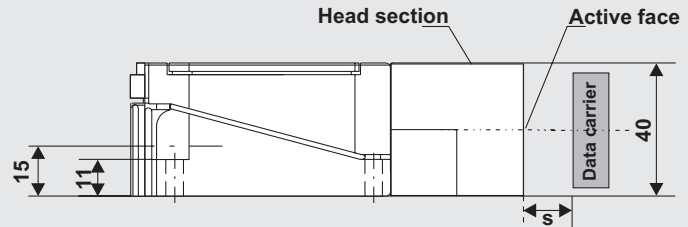
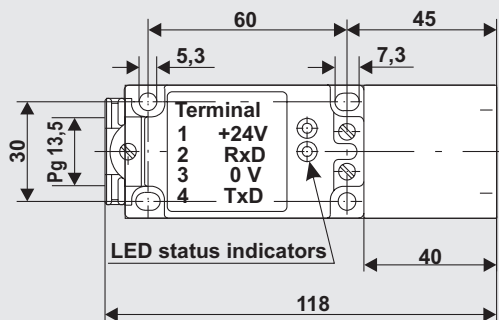

Type G05, adjustable head with 5 active face locations

All dimensions in mm

The robust housing with the environmental protection IP65 agrees to the standard EN 50 041 with regard to its size.

The 3 units

- separately mountable base
- amplifier component with plug-in feature
- sensing element which can be easily rotate and positioned in up to 5 different positions

permit a simple assembly and an easy exchangeability.

The individual commands for reading and writing the data carriers follow the conventional 3964R protocol and are described in the EUCHNER CIS3 system manual (Cat. No. 071 652).

A convenient WINDOWS®-compatible PC software is available for data carrier programming.*

Technical Data

| General parameter | Value | | | Unit |
|---|---|------|------|-------|
| | min. | nom. | max. | |
| Read/write head CIT3ASX1R1G05KR | | | | |
| Housing | Plastic | | | |
| Environmental protection | IP 65 | | | |
| Storage temperature | -25 | +70 | +80 | °C |
| Operating temperature | 0 | +22 | +50 | °C |
| Operating voltage U_B (regulated, residual ripple < 2 %) | 20 | 24 | 25 | V= |
| Current consumption | | 120 | 140 | mA |
| Connection type | screw terminal | | | |
| Operating parameter when writing and reading | | | | |
| Max. read distance s_L (for more information please see page 12) | | | 25 | mm |
| Max. write distance s_S (for more information please see page 12) | | | 13 | mm |
| Write time for 4 decimal digits (= 2 byte) | | 160 | 230 | ms |
| Write time for 32 decimal digits (= 16 Byte) | | 350 | 420 | ms |
| Interface, data transmission, documentation | | | | |
| Interface | RS232 / V.24 | | | |
| Protocol | 3964R | | | |
| Data rate | | 9.6 | | kBaud |
| Parity | even | | | |
| Cable length (RS232 interface) | | | 5 | m |
| Manual for protocol 3964R | Cat. No. 071 652 | | | |
| * PC software for programming data carrier | on request or can be downloaded from the Internet http://www.euchner.de File: cip_p_e.exe | | | |

Appendix A

Pulse Timing Diagram

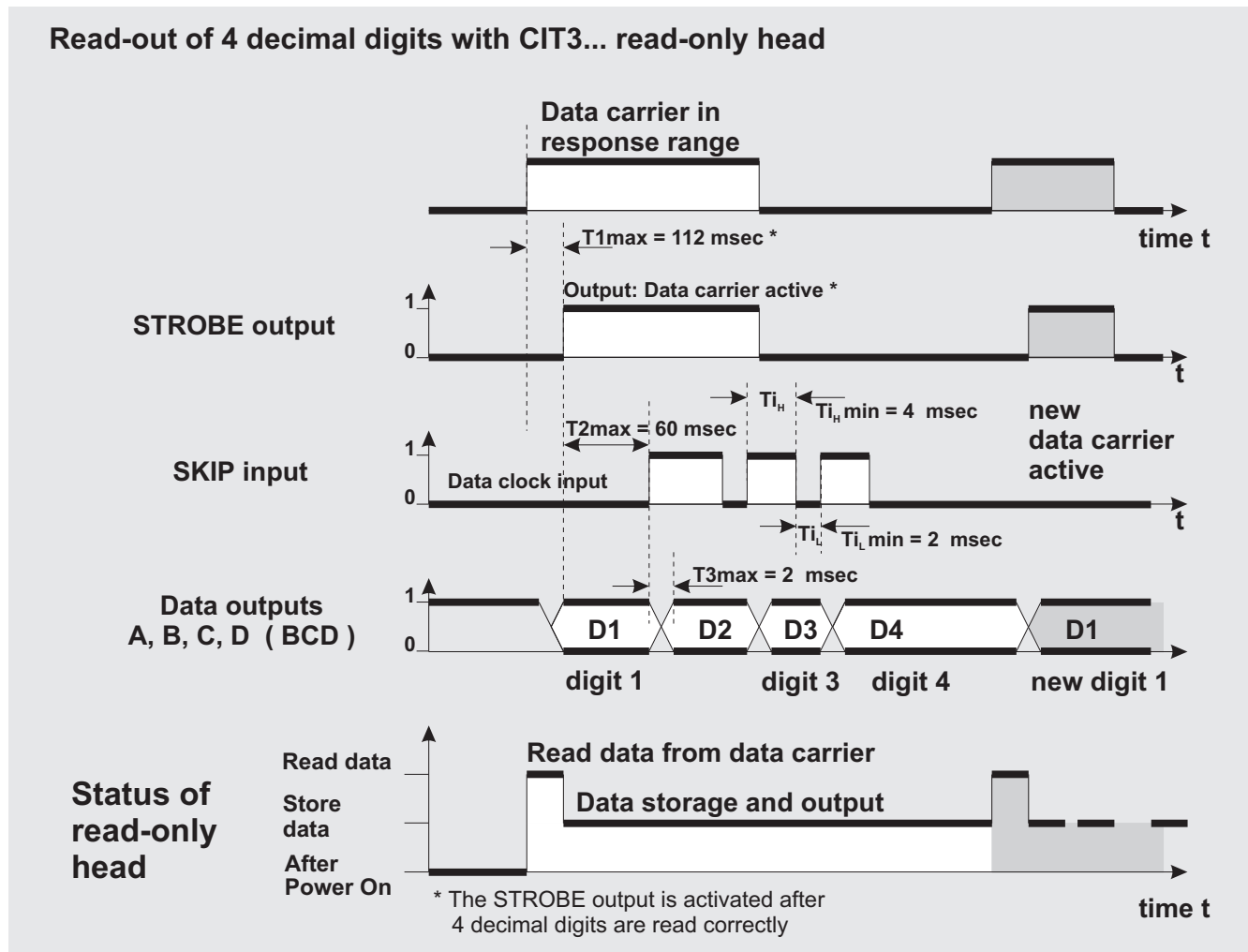

The above pulse timing diagram shows the time response of the input and output signals of the read-only head with respect to the PLC.

The read-only head stores the coded information read from one data carrier until another data carrier has been read.

The storage function offers the following advantage:

At high relative speeds between read head and data carrier, the dwell time of a data carrier in the read-only head's response range may, under certain circumstances, be shorter than the scan time of the PLC control. Owing to the storage characteristics of the read head, the code can nevertheless be read by the PLC in the next scan time cycle.

The additional STROBE output, when at HIGH level, indicates that a data carrier is located in the read head's response range.

This output is set to HIGH as soon as the read head has been able to read 4 decimal digits.

If more than 4 digits are required, it is **not** possible to check with the STROBE output whether all required digits have been read in.

If any error should occur during reading, an error message F_{hex} is given at the point in the data string. All preceding data is valid.

Note for the SKIP signal

In case the SKIP input statically is on HIGH, **no further read course** is executed.

Caused by the fact that before entry of data carrier into the response area the SKIP signal is kept on HIGH level, you can execute a "real" static reading with the change of the SKIP signal on LOW level **at this time**.

Mobile Hand-held terminal CIP3-H2 / CIP3A-H2



Mobile Hand-Held Terminal CIP3-H2 / CIP3A-H2

The mobile hand-held terminal with plug-on read/write head is a convenient complement to the EUCHNER Identsystems CIS3 and CIS3A.

The unit is equipped with a compact, removable read/write head.

In order to improve the ease of use even further, it is possible to connect the read/write head to the hand-held terminal via an optional spiral cable (Cat. No. 071 759).

The solid, splash-proof design (IP 54) ensures perfect operation even under difficult operating conditions in a tough industrial environment.

Customer-specific masks can be created for clear and individual representation of the information stored in a data carrier.

It is also possible to create the complete processing program to suit the customer's requirements (e.g.: file management, creation of a data base, graphical user interface, display of information, etc.).



- Reading, writing and editing of all EUCHNER CIS3 and CIS3A data carriers
- Read/write distance 0 to max. 12 mm (depending on the used data carrier)
- Customer-specific masks
- Operation either with batteries (2 AA cells) or with a rechargeable battery pack
- Operating time with batteries up to 40 hours
- Simple data exchange with a PC via optional docking station

Technical Data

| General parameter | Value | | | Unit |
|---|---|------|------|------|
| | min. | nom. | max. | |
| Housing | Plastic | | | |
| Environmental protection | IP 54 | | | |
| Dimensions approx.. | 250 x 90 x 35 | | | mm |
| Weight approx. (including battery pack and read/write head) | 400 | | | g |
| Storage temperature | -25 | | 70 | °C |
| Operating temperature | 0 | | 55 | °C |
| Operating voltage (battery pack or 2 AA batteries) | 3 | | | V |
| Operating time with batteries approx. | 40 | | | h |
| Memory capacity (RAM) | Standard: 2 MByte expandable up to 16 MByte | | | |
| Processor | 16 Bit NEC V30MX / 27.684 MHz (80C86 compatible) | | | |
| LCD display | DOT-Matrix display with graphics capability 240 x 100 pixels (up to 12 lines with 39 char.) backlit display | | | |
| Interface to a host PC | via integrated RS232 interface or via optional docking station | | | |

Mobile Hand-Held Terminal CIP3-H2 / CIP3A-H2



The hand-held terminal can also be equipped with a docking station (Cat. No. 071 761), which permits a comfortable data transfer between a PC and the hand-held terminal.

For the hand-held terminal a large selection of accessories are available.

The required hand-held terminal can be assembled according to the kit principle.

With the basic complement, a hand-held terminal consist of the basic unit (Psion-Workabout), a read/write head and a standard software module.

This software module can be used to read and write CIS3 / CIS3A data carriers and to edit data on the display.

A customer-specific software adaption is available within a short time at a low extra charge.

This is possible, even if only one unit is purchased.

Parts list and accessories

| Part designation | Cat. No. |
|---|----------|
| Basic unit (Psion-Workabout) (Basic unit , batteries included, without read/write head and without software) | 071 760 |
| Read/write head CIT3-H2 | 071 755 |
| Read/write head CIT3A-H2 | 071 778 |
| CIS3 standard software | 071 976 |
| CIS3A standard software | 071 978 |
| Manual for CIS3 standard software | 071 977 |
| Manual for CIS3A standard software | 071 979 |
| Rechargeable battery pack (can be charged only in the optional docking station) | 071762 |
| Spiral connection cable Read/write head ⇔ Hand-held terminal | 071759 |
| Docking station including connecting cable and PC software (For simple data transfer between the hand-held terminal and a PC and simultaneous charging of the optional rechargeable battery pack) | 071761 |